



Hirth-Information

Mitteilung-Nummer:

0060/3N

Inhalt:

Exhaust System Assemblies
(2-cylinder boxer engines F23)

Datum:

19.05.2003

Basic System:

Version 1a (Nr.: 278 X31U):

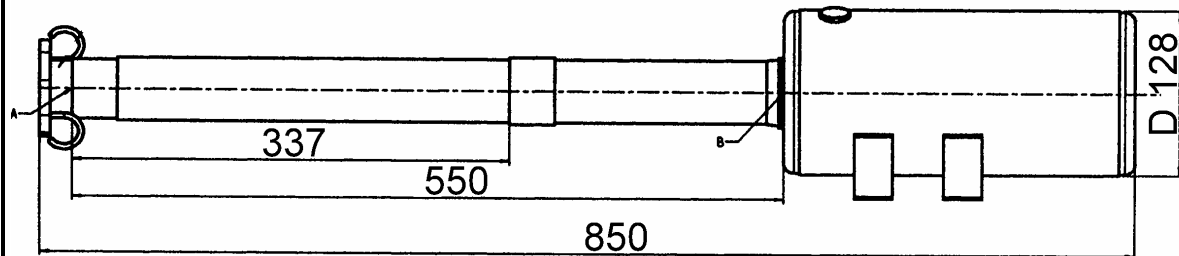

Version 1b (278 X32U):

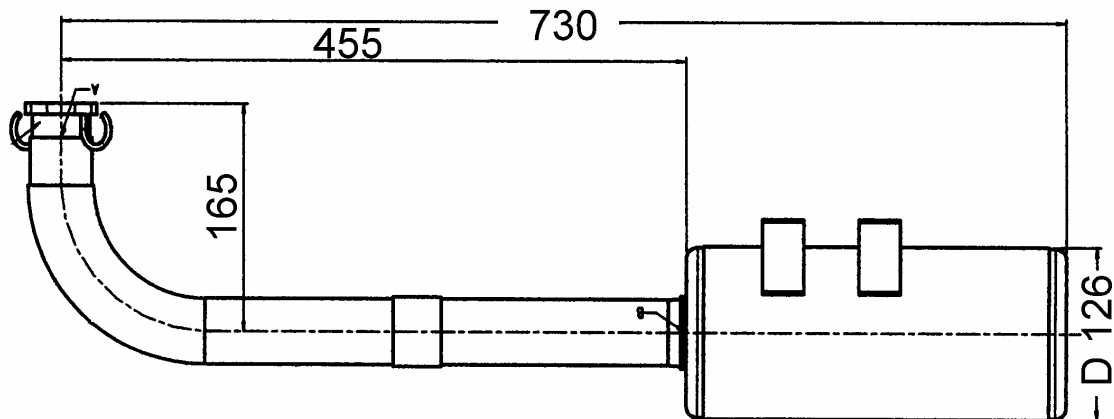

Version 1b (278 X33U):

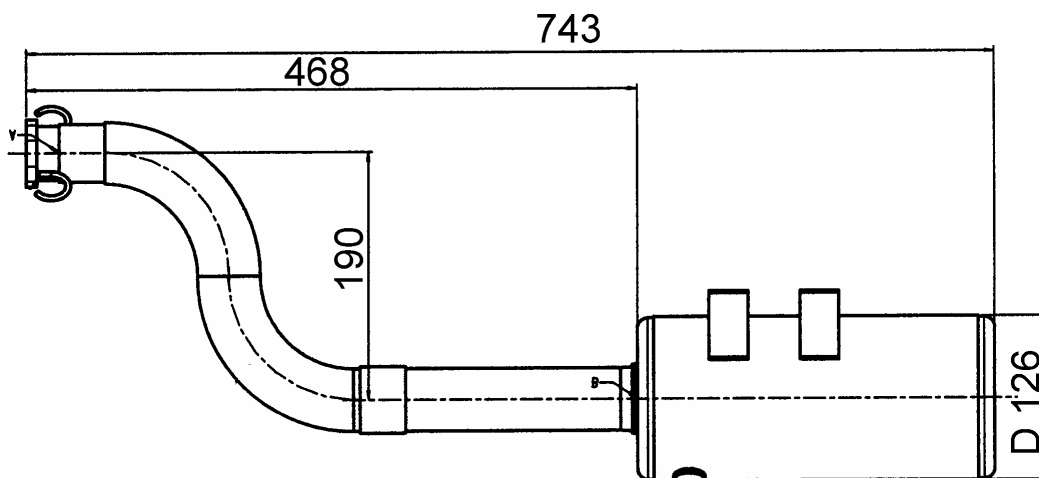

Version 2a (278 X34U):

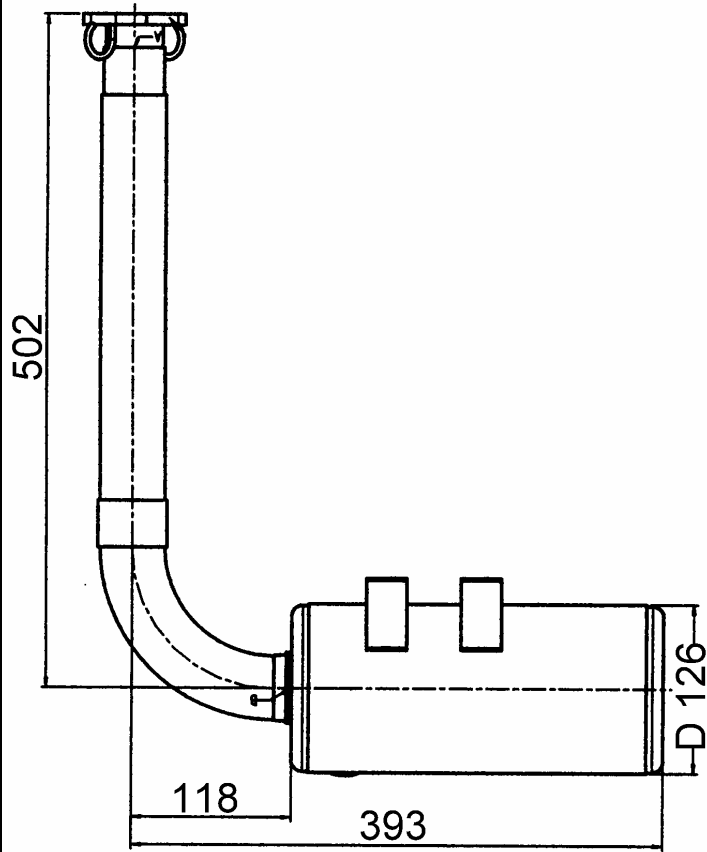

Version 2b (278 X35U):

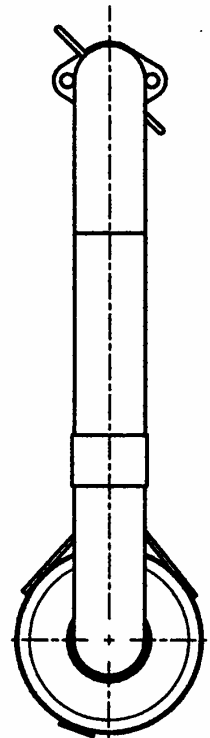
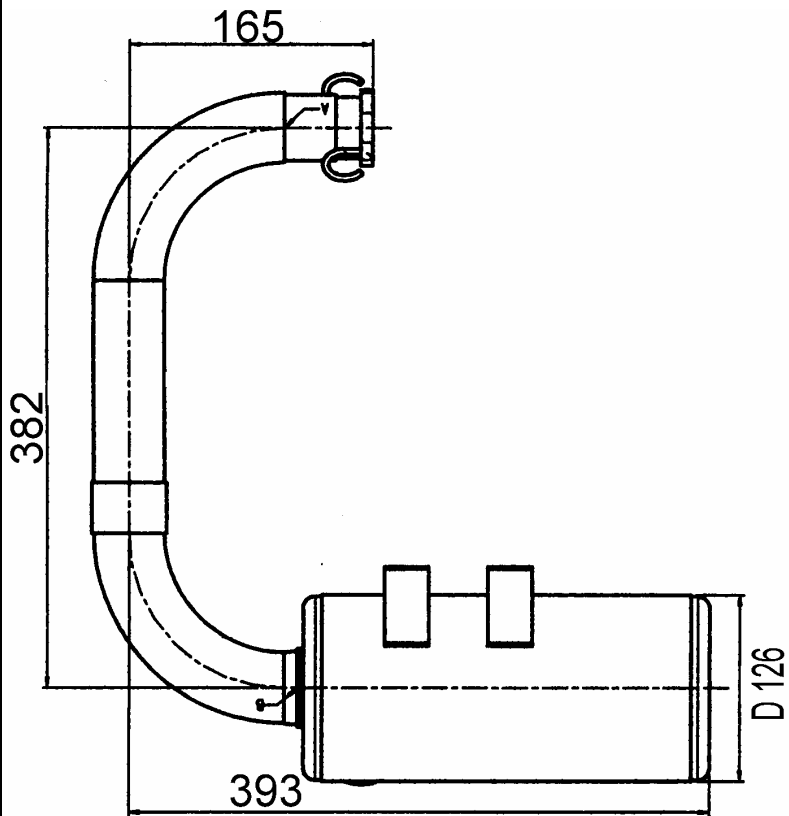

Version 2c (278 X36U):

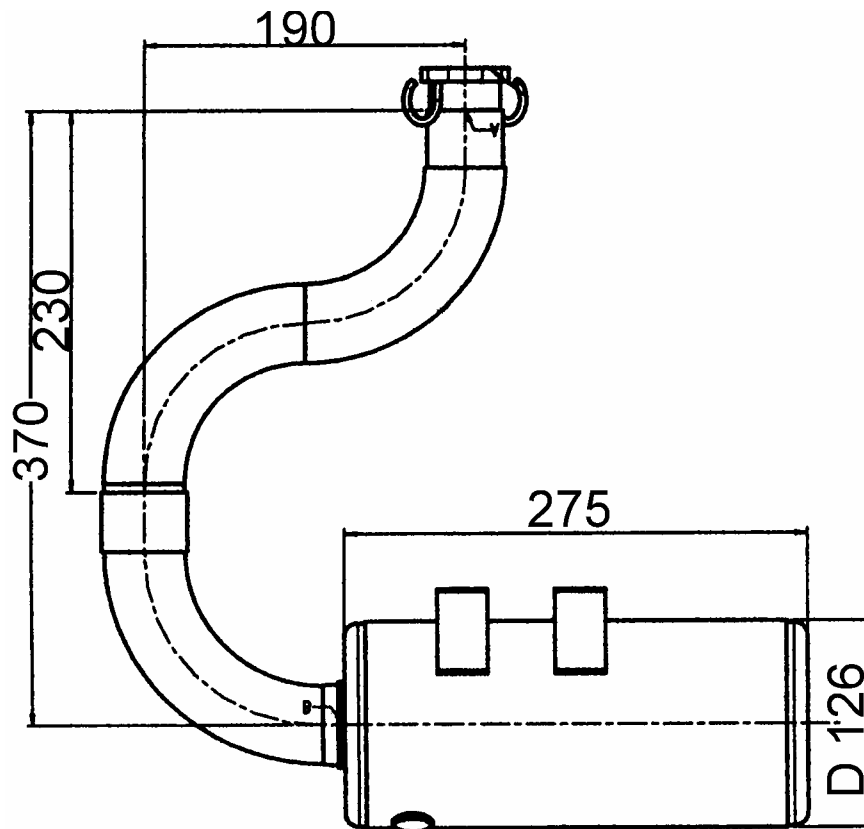

Note:

The exhaust tubes can be turned on all three connecting points thus allowing the better adaptation to the situation of installation.

The eyes (278X54) have to be welded at the connecting points so that the springs (018.11/3) can be hooked in .

If none of the 6 exhaust versions is usable, it is possible to adjust a cylindrical tube with internal diameter of 45mm on condition that the tube length of 550mm between the exhaust muffler (278X60U) and the connecting flange (278X52U) is kept up. The connecting flange must be slipped in into the exhaust tube up to 26mm.

The weight of the exhaust system for each cylinder is 2,2 kg.

Parts of exhaust system

278 X60U exhaust muffler, complete

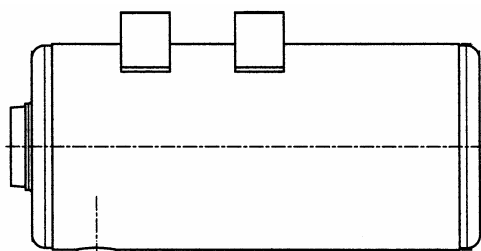

278 X39U 90° bow

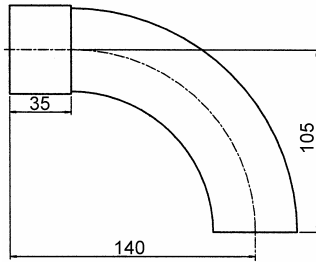

278 X50U exhaust muffler with connecting tube straight

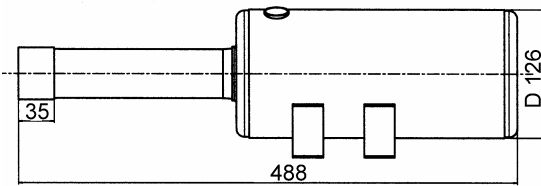

278 X41U intermediate tube, complete

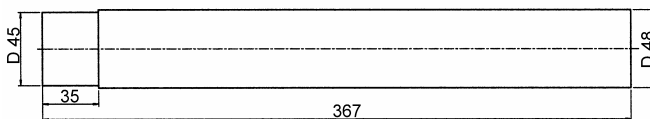

278 X43U 90° intermediate bow, complete

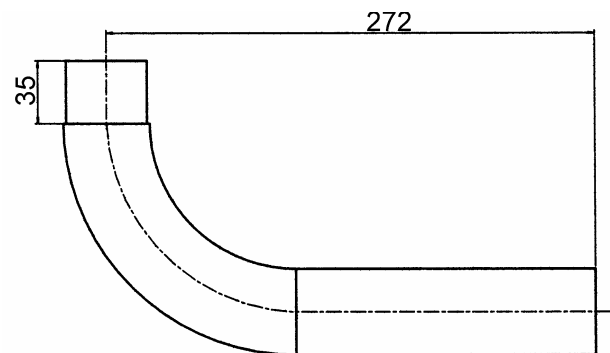

278 X45U tube bow, S-shaped

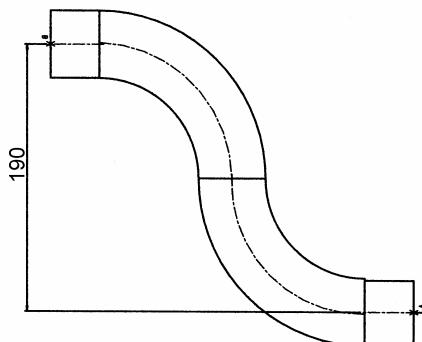

278 X52U outlet flange with tube

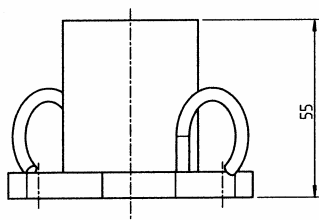

278 X54Eye



018.11/3 Spring



Please note that the specified / pretended performance can't be guaranteed if any exhaust version is used for the engine differing from the 6 basic versions stated above. Any modifications of the exhaust system might result in damage of the engine and in that case we are not obliged to give warranty or guarantee.