

## 02<ROTAX EXHAUST SYSTEM>ROTAXマフラー関係

### ☆ROTAX 377. 447. 503. 532. 582 サイドマウント タイプ

#### ●377. 447用

No.	商品	商品番号	価格	数
1	Spring 66 MM	938-795	¥ 1,230	6
2	Gasket Ring A 8X13 DIN 7603	950-141	¥ 220	2
3	Capstan Screw M8X1X10	941-615	¥ 1,380	2
4	Exhaust Manifold Assembly(フォーク付)	979-380	¥ 43,170	1
5	Connecting Elbow Assembly(フォーク無し)	973-180	¥ 26,990	1
5	Connecting Elbow Assembly(フォーク付)	973-182	¥ 29,970	1
6	Muffler Assembly(フォーク付)	973-198	¥ 83,980	1
7	Hook	853-355	¥ 330	1
9	Gasket 1, 0 MM	850-114	¥ 1,590	4
10	Lock Washer A8	945-752	¥ 30	4
11	Allen Screw M8X30	840-991	¥ 230	4

#### ●503用

No.	商品	商品番号	価格	数
1	Spring 66 MM	938-795	¥ 1,230	6
2	Gasket Ring A 8X13 DIN 7603	950-141	¥ 220	2
3	Capstan Screw M8X1X10	941-615	¥ 1,380	2
4	Exhaust Manifold Assembly(フォーク付)	878-937	¥ 31,750	1
5	Connecting Elbow Assembly(フォーク無し)	973-180	¥ 26,990	1
5	Connecting Elbow Assembly(フォーク付)	973-182	¥ 29,970	1
6	Muffler Assembly(フォーク付)	973-198	¥ 83,980	1
7	Hook	853-355	¥ 330	1
8	Exhaust Manifold Assembly	879-144		
9	Gasket 1, 0 MM	831-849	¥ 1,680	4
10	Lock Washer A8	945-752	¥ 30	4
11	Allen Screw M8X30	840-991	¥ 230	4

#### ●532. 582用

No.	商品	商品番号	価格	数
1	Return Spring	938-790	¥ 1,470	6
2	Gasket Ring A 8X13 DIN 7603	950-141	¥ 220	2
3	Capstan Screw M8X1X10	941-615	¥ 1,380	2
4	Exhaust Manifold Assembly(フォーク無し)	973-121	¥ 41,870	1
4	Exhaust Manifold Assembly(フォーク付)	973-123	¥ 42,640	1
5	Connecting Elbow Assembly(フォーク無し)	973-180	¥ 26,990	1
5	Connecting Elbow Assembly(フォーク付)	973-182	¥ 29,970	1
6	Muffler Assembly(フォーク無し)	973-197	¥ 83,980	1
7	Hook	853-355	¥ 330	1
9	Exhaus Gasket	850-633	¥ 2,190	2
10	Lock Washer A8	945-752	¥ 30	6
11	Allen Screw M8X30	840-991	¥ 230	6

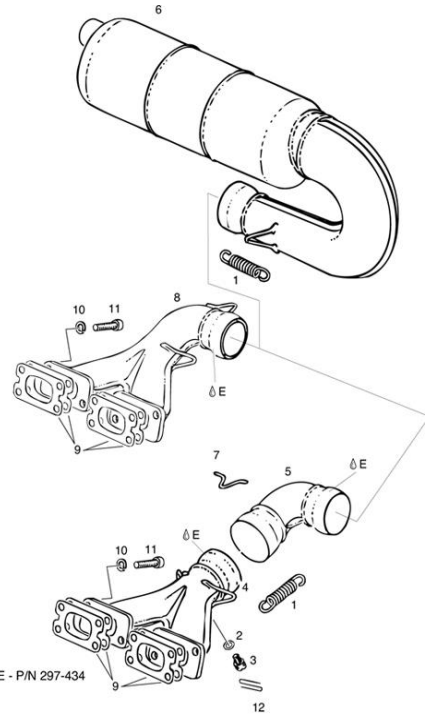

FOR CHART BELOW:  
a WITHOUT HOOKS  
b WITH HOOKS  
c SEE ALSO SI-2ST-002  
d NO LONGER IN AVAILABLE

### ☆ROTAX 618 サイドマウント タイプ

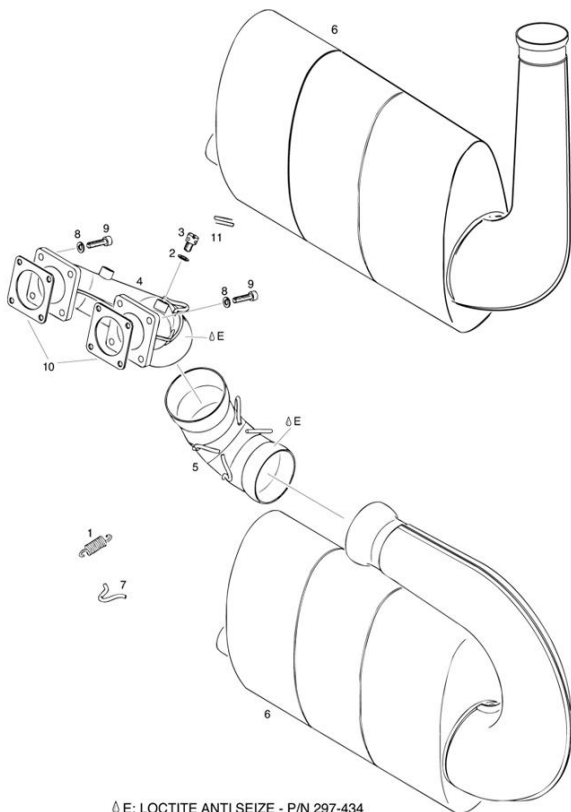

No.	商品	商品番号	価格	数
1	Spring 66 MM	938-795	¥ 1,230	6
2	Gasket Ring A 8X13 DIN 7603	950-141	¥ 220	2
3	Capstan Screw M8X1X10	941-615	¥ 1,380	2
4	Exhaust Manifold Assembly(フォーク付)	979-210		1
5	Connecting Elbow Assembly(フォーク付)	973-183	¥ 27,240	1
6	Muffler Assembly(フォーク無し)サイドマウント	978-840		1
6	Muffler Assembly(フォーク無し)L型	978-845	¥178,170	1
7	Hook	853-355	¥ 330	1
8	Lock Washer A6 DIN 128	945-751	¥ 30	8
9	Allen Screw	840-861	¥ 200	8
10	Exhaus Gasket	850-552	¥ 1,840	2

- No. 6#973-840は180° (サイドマウント)タイプです。
- No. 6#973-845は90° (L型)タイプです。

FOR CHART BELOW:  
a WITHOUT HOOKS  
b WITH HOOK  
c SEE ALSO SI-2ST-002  
\* CALL FOR PRICING!